

MOUNTING INSTRUCTION

2021-05-26

38-304600c



21-588078

21-588178

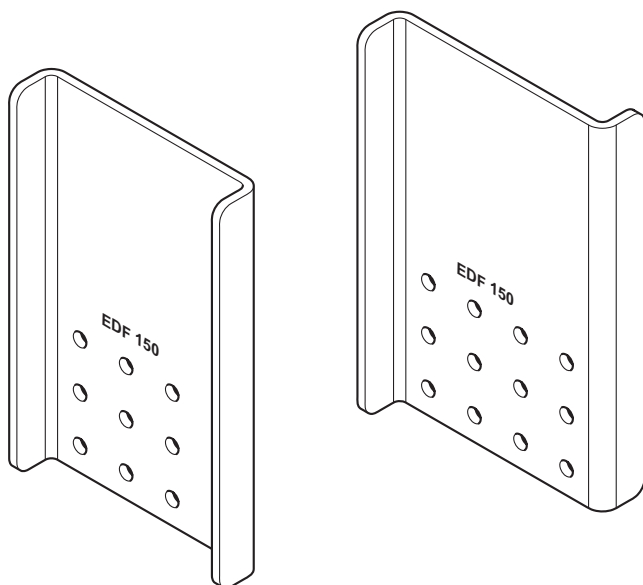

- DE** Platte EDF 150, EDF 150 Tipper
- DK** Gavl EDF 150, EDF 150 Tipper
- EE** Plaat EDF 150, EDF 150 Tipper
- FI** Sivulevy EDF 150, EDF 150 Tipper
- FR** Flasque EDF 150, EDF 150 Tipper
- GB** Endplate EDF 150, EDF 150 Tipper

- LV** Frontons EDF 150, EDF 150 Tipper
- NL** Eindstuk EDF 150, EDF 150 Tipper
- NO** Gavl EDF 150, EDF 150 Tipper
- PL** Płyta EDF 150, EDF 150 Tipper
- RU** Фронтон EDF 150, EDF 150 Tipper
- SE** Gavel EDF 150, EDF 150 Tipper



Montageanleitung
Monteringvejledning
Paigaldusjuhend
Asennusohje

Instructions de montage
Mounting instruction
Montāžas instrukcija
Montagehandleiding

Monteringsanvisning
Instrukcja montażowa
Указания по монтажу
Monteringsanvisning



Visuelle Kontrolle
Visuel kontrol
Visuaalne kontroll
Silmämääräinen tarkastus

Contrôle visuel
Visual check
Vizuālā pārbaude
Visuele controle

Visuell kontroll
Kontrola wzrokowa
Визуальный контроль
Visuell kontroll



Anweisungen des LKW-Herstellers
Lastbilfabrikantens anvisning
Haagise tootja juhised
Ajoneuvon valmistajan ohjeet
Indications du constructeur du véhicule
Vehicle manufacture instruction

Autorūpnīcas instrukcija
Instructies vrachtwagenfabrikant
Lastebilprodusentens anvisning
Instrukcja producenta pojazdu
Указание изготовителя грузового автомобиля
Lastvagnstillverkarens anvisning



Information, sehen Referenzmaß für Lochbohrung
Information, se boreskabelon
Teave, vt puurimismalli
Tiedot, ks. porausmalli
Information, voir le gabarit de perçage
Information, see drilling plan

Informācija, skatīt urbšanas paraugu
Informatie, zie boormal
Informasjon, se bormal
Informācija, patrz wzorzec otworów
Информация, см. шаблон сверления
Information, se bormall

DE

Allgemeines

Identifizieren Sie vor der Montage alle Teile. Montage und Wartung müssen genau und fachmännisch durchgeführt werden. Die Anweisungen und etwaigen Rahmenverstärkungen des Fahrzeugherstellers müssen beachtet werden. Übergeben Sie alle Anweisungen und Anleitungen dem Kunden, damit dieser die Unterlagen für spätere Wartung und Pflege im Fahrzeug verwahren kann. Weitere Informationen finden Sie auf unserer Homepage: www.vbg.eu.

DK

Generelt

Identificer alle dele før montering. Montering og service skal udføres omhyggeligt og på en faglig korrekt måde. Bemærk at der skal tages hensyn til bilfabrikantens vejledninger og eventuelle ramme-forstærkninger. Giv kunden alle anvisninger og instruktioner, så de kan opbevares i bilen med henblik på fremtidig service og vedligeholdelse. Yderligere information findes på vores hjemmeside www.vbg.eu.

EE

Üldist

Identifitseerige enne montaaži kõik osad. Paigaldus ja hooldus tuleb teostada hoolikalt ja professionaalselt. Pange tähele, et arvesse tuleb võtta ka sõiduki tootja juhiseid ja võimalikke ettekirjutusi raamitugevduste osas. Andke juhi käsiraamat kliendile kaasa sõidukis säilitamiseks, et see oleks käepärast hilisemate hoolduste korral. Täiendava teabe saamiseks külastage meie kodulehte www.vbg.eu.

FI

Yleistä

Tarkasta kaikki osat ennen asennusta. Asennus ja huolto tulee tehdä huolellisesti ja ammattitaidolla. Huomioi ajoneuvon valmistajan ohjeet asennuksesta ja mahdollisista vahvistuksista. Luovuta kaikki ohjeet asiakkaalle ajoneuvossa säilytettäväksi tulevia huoltoja ja kunnossapitoa varten. Lisätietoja löytyy kotisivuiltamme www.vbg.eu.

FR

Généralités

Identifier toutes les pièces avant le montage. Le montage et l'entretien doivent être effectués avec le plus grand soin et selon les instructions recommandées. Observer que les instructions du constructeur du véhicule et les éventuels renforts du cadre doivent impérativement être respectés. Remettre toute la documentation au client. Elle doit être conservée dans le véhicule pour les entretiens et maintenances ultérieurs. Pour plus d'informations, consultez notre site Web www.vbg.eu.

GB

General

Identify all parts before installation. Installation shall be done in a proper and competent manner. The truck manufacturer's body building instructions must be observed. All directives and instructions should be kept in the vehicle for future service and maintenance. For more information, go to our website: www.vbg.eu.

LV

Vispārēja informācija

Pirms uzstādīšanas identificējiet visas detaļas. Uzstādīšana veicama rūpīgi un kompetenti. Jāievēro kravas automašīnas ražotāja korpusa montāžas instrukcijas. Visus norādījumus un instrukcijas, kas būs nepieciešamas servisam un apkopei, nododiet klientam, lai tās tiktu uzglabātas transporta līdzeklī. Lai saņemtu vairāk informācijas, skatiet mūsu mājaslapu www.vbg.eu

NL

Algemeen

Voor de montage moet u alle onderdelen identificeren. Voer montage en service zorgvuldig en deskundig uit. Let op dat rekening moet worden gehouden met de aanwijzingen van de voertuigfabrikant en eventuele chassisverstevingen. Laat de klant alle aanwijzingen en instructies in het voertuig bewaren, zodat deze voor toekomstige service en onderhoud beschikbaar zijn. Ga voor meer informatie naar onze website www.vbg.eu.

NO

Generelt

Identifiser alle deler før montering. Montering og service skal utføres nøyaktig og fagmessig. Observer at det må tas hensyn til kjøretøyproduzentens anvisninger og eventuelle rammeforsterkninger. Overlever alle anvisninger og instruksjoner til kunden for oppbevaring i kjøretøyet for fremtidig service og vedlikehold. Gå til hjemmesiden vår, www.vbg.eu, for mer informasjon.

PL

Informacje ogólne

Zapoznaj się z poszczególnymi częściami przed przystąpieniem do montażu. Czynności montażowe i serwisowe należy wykonywać dokładnie i fachowo. Zauważ, że konieczne jest stosowanie się do instrukcji producenta pojazdu oraz uwzględnienie ewentualnych wzmocnień ramy. Wszystkie wskazówki i instrukcje należy przekazać klientowi w celu przechowywania ich w pojeździe do wykorzystania przy okazji przyszłych czynności serwisowych i konserwacyjnych. Dodatkowe informacje znajdują się na naszych stronach internetowych www.vbg.eu.

RU

Общая информация

Перед монтажом, проверьте наличие всех деталей. Монтаж и обслуживание должны осуществляться тщательно и профессионально. Заметьте, что должны учитываться и приниматься во внимание возможные усиления рамы, сделанные изготовителем транспортного средства. Передайте клиенту все указания и инструкции для хранения их в машине для обслуживания и сервисных работ в будущем. Для получения дополнительной информации, посетите наш веб-сайт www.vbg.eu.

SE

Allmänt

Identifiera alla delar före montering. Montering och service skall utföras noggrant och fackmannamässigt. Notera att fordonstillverkarens anvisningar och eventuella ramförstärkningar måste beaktas. Lämna alla anvisningar och instruktioner till kunden att förvaras i fordonet för framtida service och underhåll. För mer information, gå in på vår hemsida www.vbg.eu.

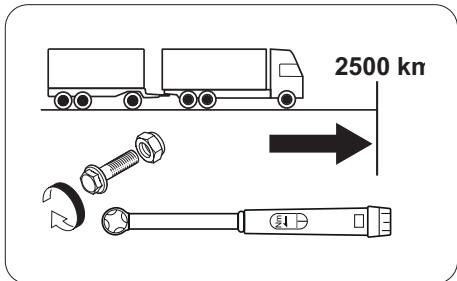
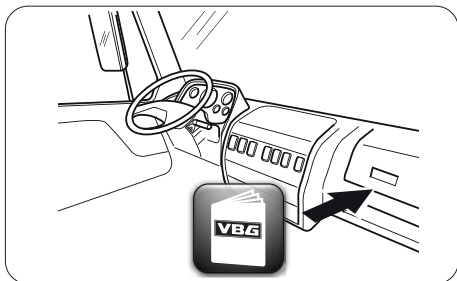
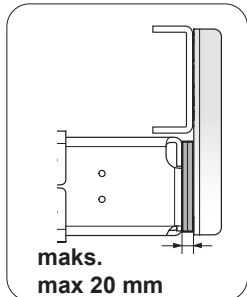
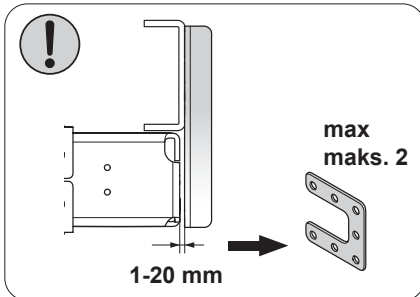
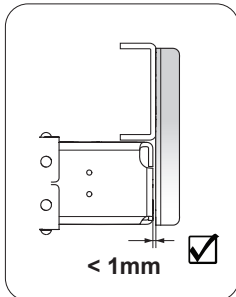
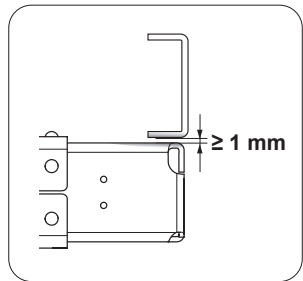
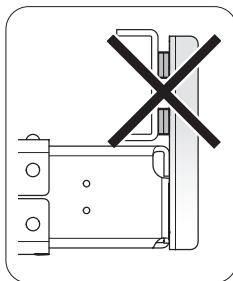
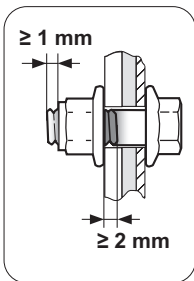
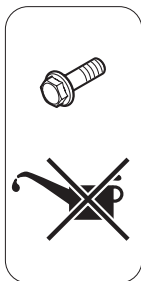
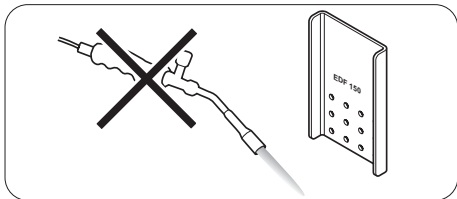
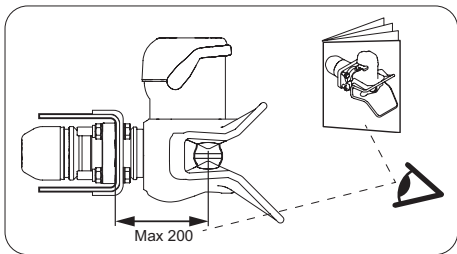
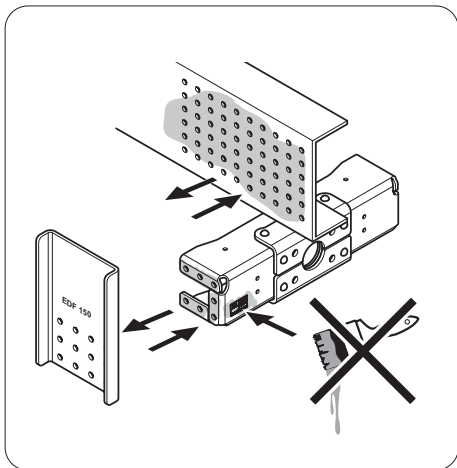

2.

Ø 17-17,5 mm

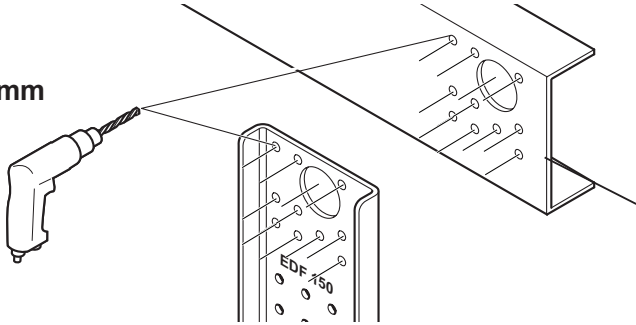

3.

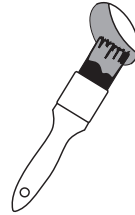
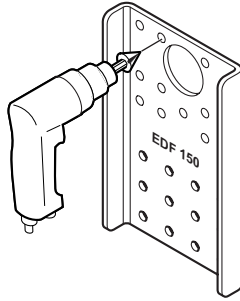
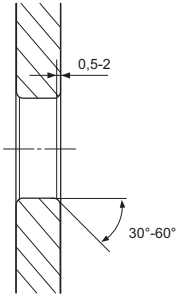

4.

EDF 150 + EUP-180/
EUR-180



≥ 20 x M16 (10.9)

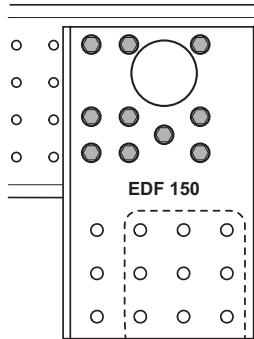
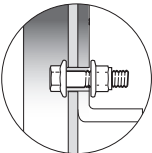
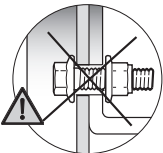

EUP-180
EUR-180

EDF 150



≥ 20 x M16
(10.9)



250 Nm

EUP-180 EUR-180

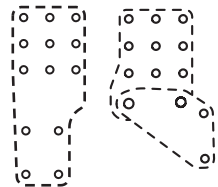

38-324100

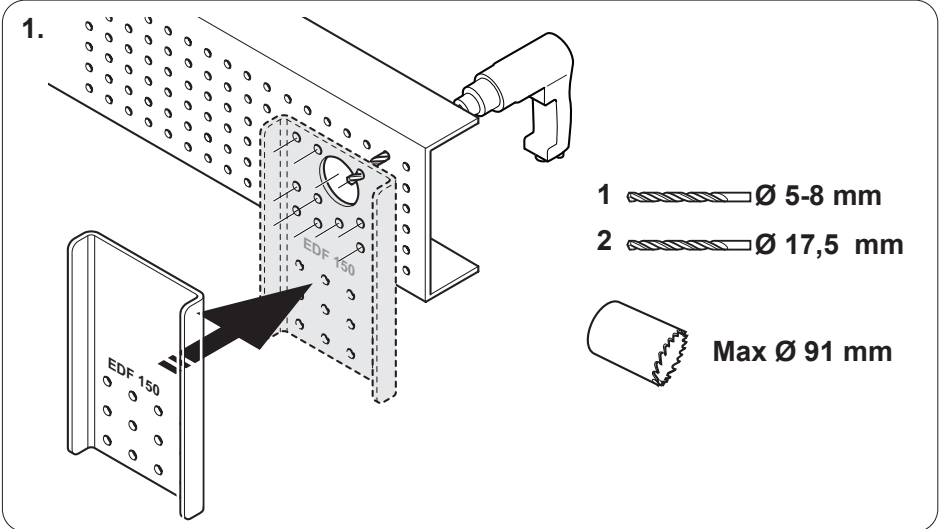
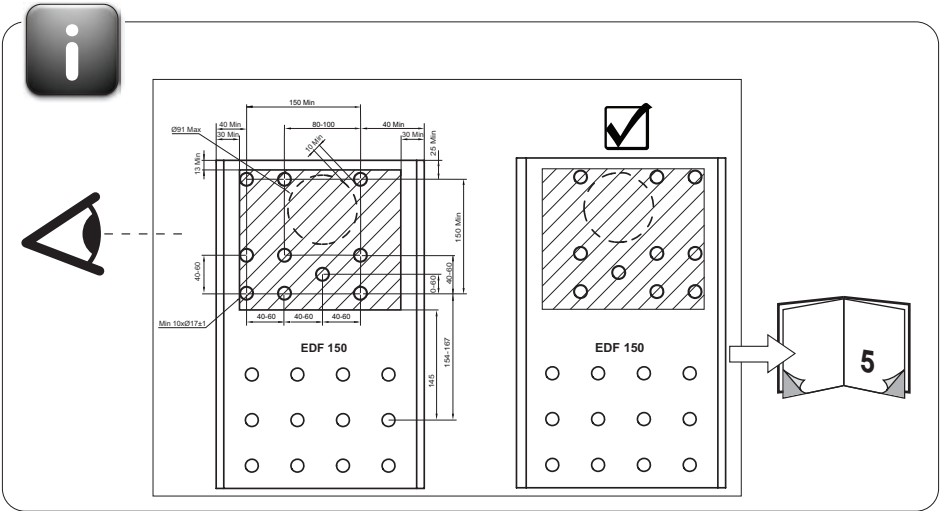
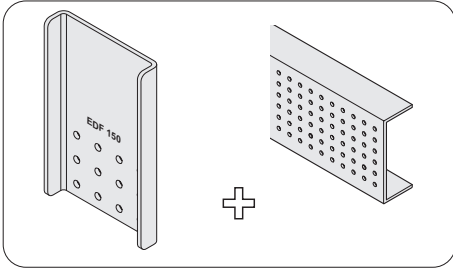

2.

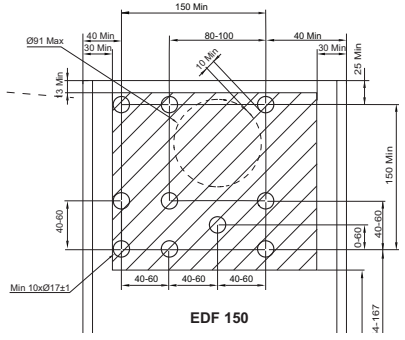
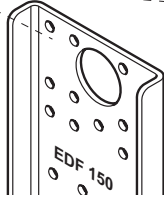

EDF 150

3.

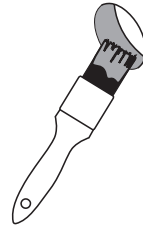
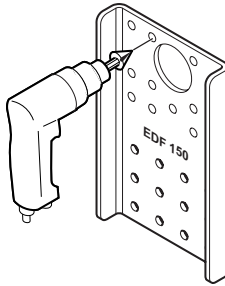
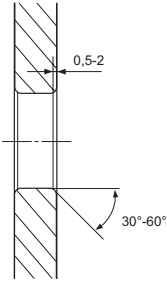

4.

EDF 150 + EUP-180/
EUR-180



$\geq 20 \times M16$ (10.9)

250 Nm

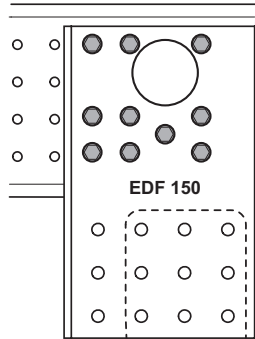
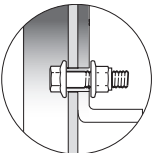
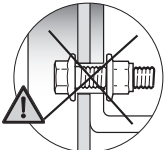

EDF 150

EUP-180
EUR-180

EDF 150



$\geq 20 \times M16$
(10.9)



250 Nm

EUP-180 EUR-180

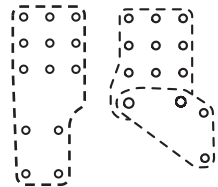

38-324100

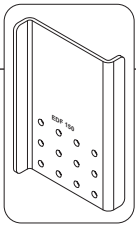

21-588178

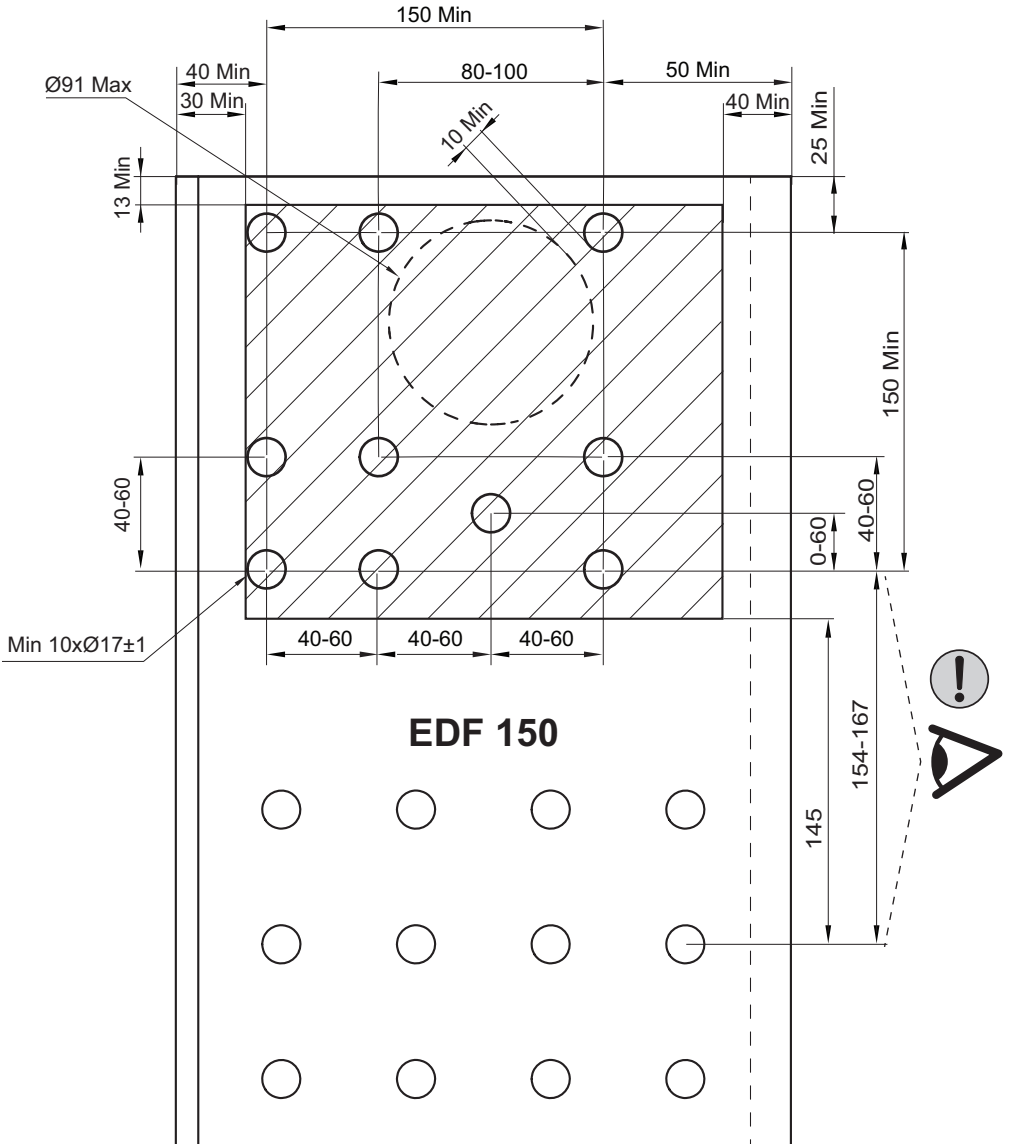

2.

Ø 17-17,5 mm

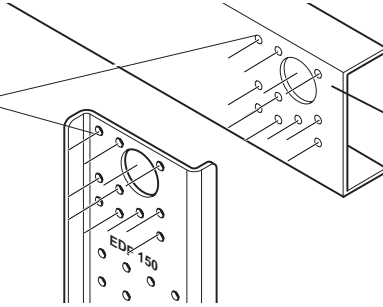

3.

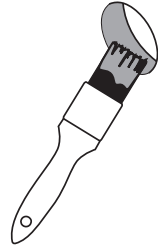
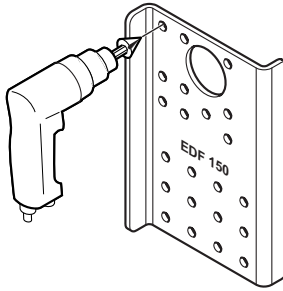
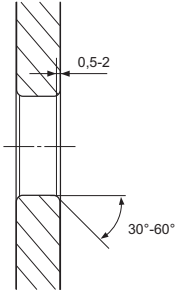

4.

**EDF 150 + EUP-180/
EUR-180**



≥ 20 x M16 (10.9)

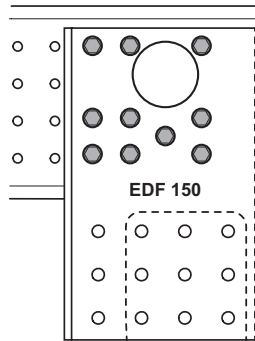
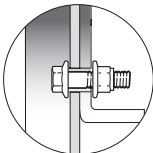
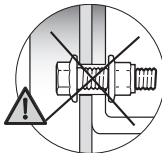

**EUP-180
EUR-180**

EDF 150



≥ 20 x M16
(10.9)



250 Nm

EUP-180 EUR-180

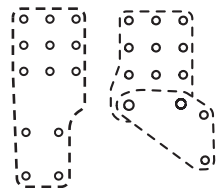

38-324100

2.

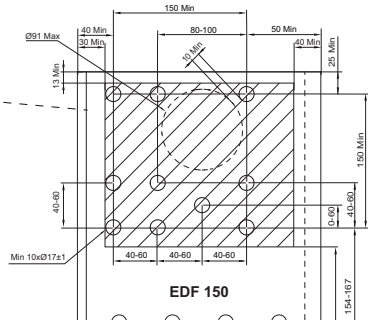
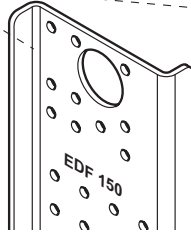

3.

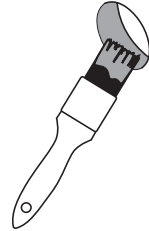
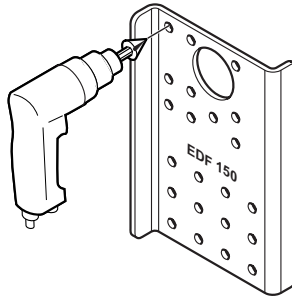
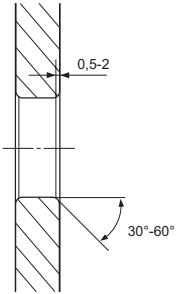

4.

**EDF 150 + EUP-180/
EUR-180**



≥ 20 x M16 (10.9)

250 Nm

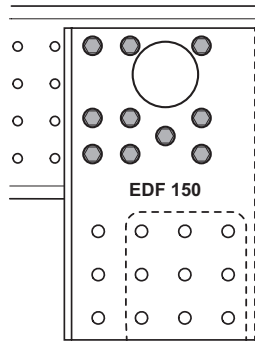
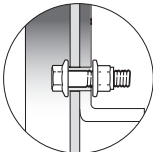
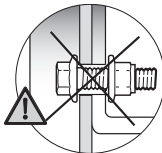

**EUP-180
EUR-180**

EDF 150



**≥ 20 x M16
(10.9)**



250 Nm

EUP-180 EUR-180

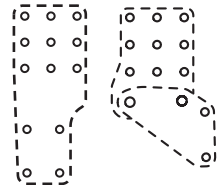

38-324100

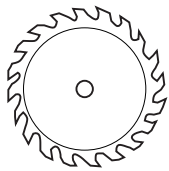

21-588078

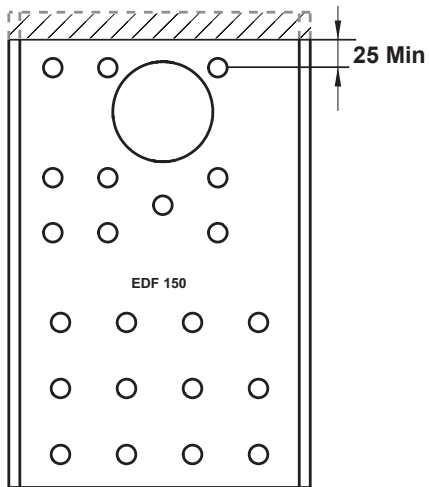

21-588178

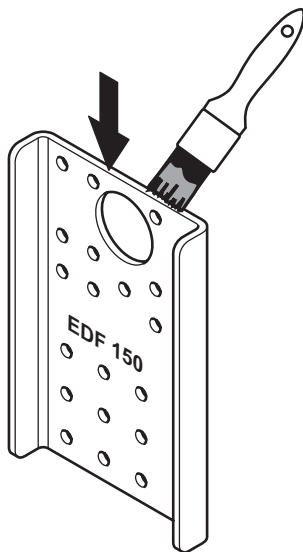
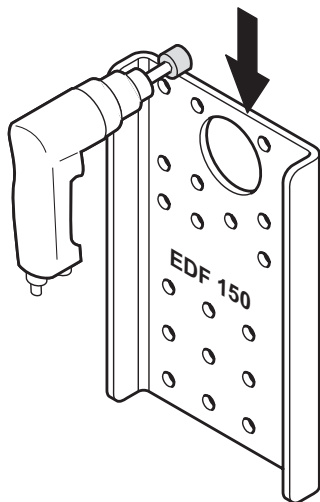
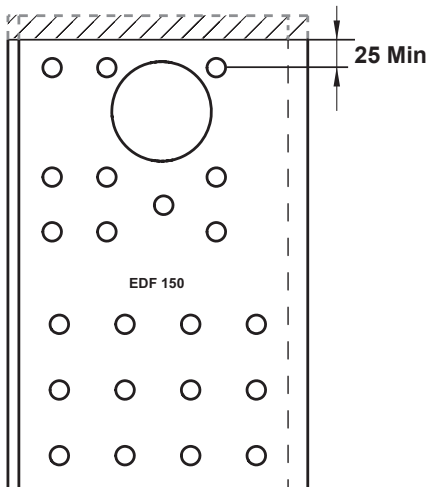



DB 75V-2

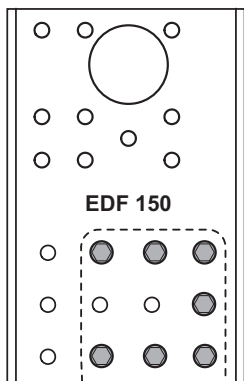
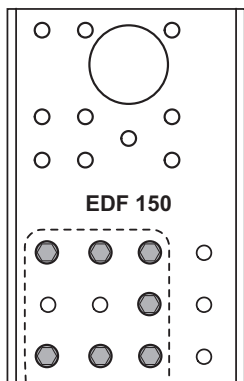
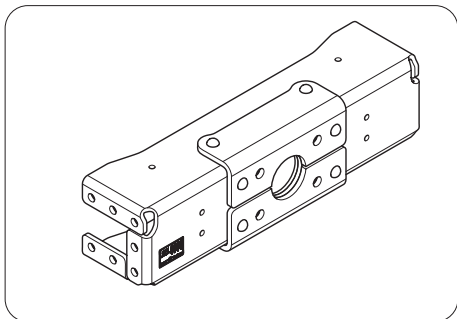

**14 x M16
(10.9)**



250 Nm

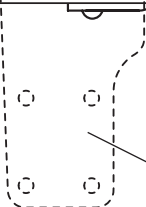

**EUP-180
EUR-180**

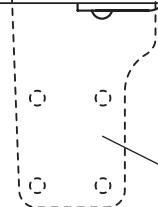

**EUP-180
EUR-180**

Member of VBG GROUP

www.vbg.eu



The strong connection