

# MOUNTING INSTRUCTION

2021-01-28 38-340300a

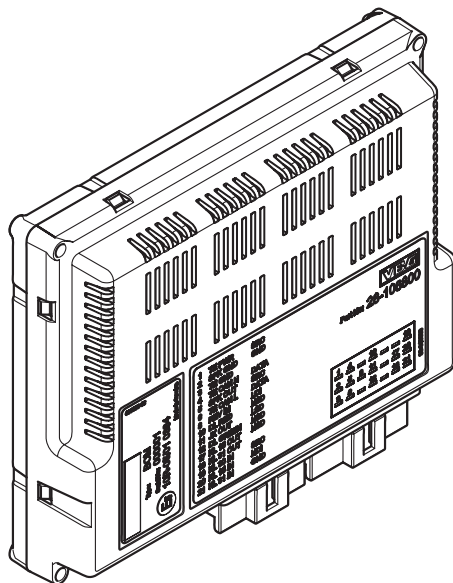

## 28-116400



DE

BCM, elektronische Einheit

DK

BCM, elektronisk enhed

EE

BCM, elektrooniline üksus – varuosa

FI

BCM, elektroninen yksikkö

FR

BCM, unité électronique – pièce de rechange

GB

BCM, electronic unit

LV

BCM, elektroniskais bloks – rezerves daļa

NL

BCM, elektronische unit – reserveonderdeel

NO

BCM, elektronisk enhet

PL

BCM, jednostka elektroniczna – część zamienna

RU

BCM, электронный блок – запасная часть

SE

BCM, elektronisk enhet



Montage  
Montering  
Paigaldus  
Asennus

Montage  
Mounting  
Montāžas  
Montage

Montering  
Montażowa  
монтажу  
Montering



Funktionskontrolle  
Funktionskontrol  
Talitluskontroll  
Toiminnan tarkastus

Vérification des fonctions  
Function check  
Darbības pārbaude  
Functiecontrole

Funksjonskontroll  
Kontrola działania  
Контроль функций  
Funktionskontroll



Klemmgefahr!  
Klemmerisiko!  
Muljumisoht!  
Puristumisvaara!

Risque d'écrasement!  
Pinch point!  
Traumu risks!  
Risiko op beknelling!

Klemfare!  
Ryzyko zakleszczenia!  
Риск защемления!  
Klāmrisk!



Visuelle Kontrolle  
Visuel kontrol  
Visuaalne kontroll  
Silmämääräinen tarkastus

Contrôle visuel  
Visual check  
Vizuālā pārbaude  
Visuele controle

Visuell kontroll  
Kontrola wzrokowa  
Визуальный контроль  
Visuell kontroll

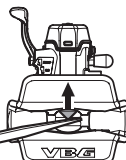
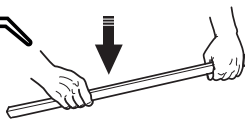
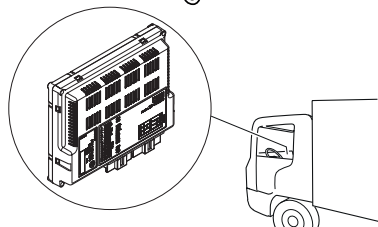
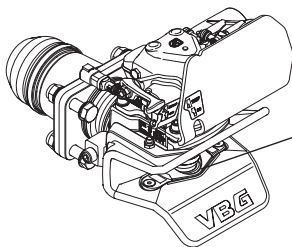

- 
- DE** **Allgemeines**  
Vor der Montage alle Teile identifizieren. Montage und Wartung müssen sorgfältig und fachmännisch durchgeführt werden.
- DK** **Generelt**  
Kontroller at alle dele er til stede inden montering. Montering og service skal foretages omhyggeligt og fagmæssigt.
- EE** **Üldist**  
Määratlege kõik osad enne monteerimist. Paigaldus ja hooldus tuleb teostada hoolikalt ja professionaalselt.
- FI** **Yleistä**  
Tunnista kaikki osat ennen asennusta. Asennus ja huolto on suoritettava huolellisesti ja ammattimaisesti.
- FR** **Généralités**  
Le montage et l'entretien doivent être effectués avec le plus grand soin et selon les règles de l'art.
- GB** **General**  
Identify all parts before installation. Installation and service shall be carried out carefully and professionally.
- LV** **Vispārēja informācija**  
Pirms montāžas identificējiet visas detaļas. Montāža un serviss ir jāveic rūpīgi un profesionāli.
- NL** **Algemeen**  
Voor de montage moet u alle onderdelen identificeren. Voer montage en service zorgvuldig en deskundig uit.
- NO** **Generelt**  
Identifiser alle deler før montering. Montering og service skal utføres nøyaktig og fagmessig.
- PL** **Informacje ogólne**  
Zapoznaj się z poszczególnymi częściami przed przystąpieniem do montażu. Czynności montażowe i serwisowe należy wykonywać dokładnie i fachowo.
- RU** **Общая информация**  
Перед монтажом проверьте наличие всех деталей. Монтаж и обслуживание должны осуществляться тщательно и профессионально.
- SE** **Allmänt**  
Identifiera alla delar före montering. Montering och service skall utföras noggrant och fackmannamässigt.

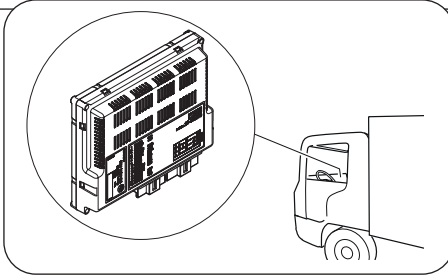

1.

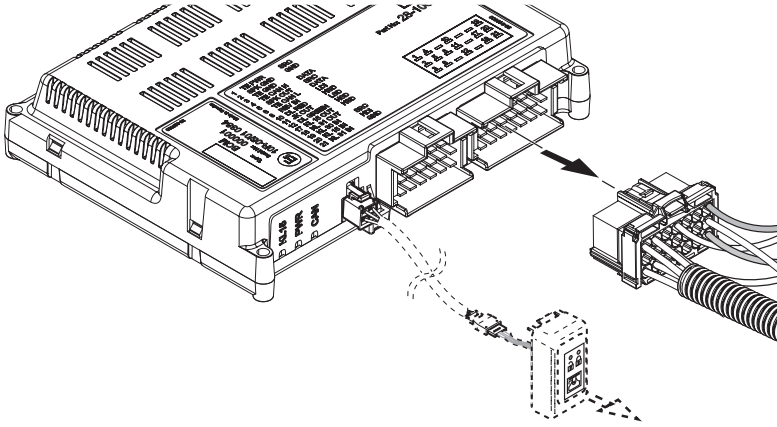

2.

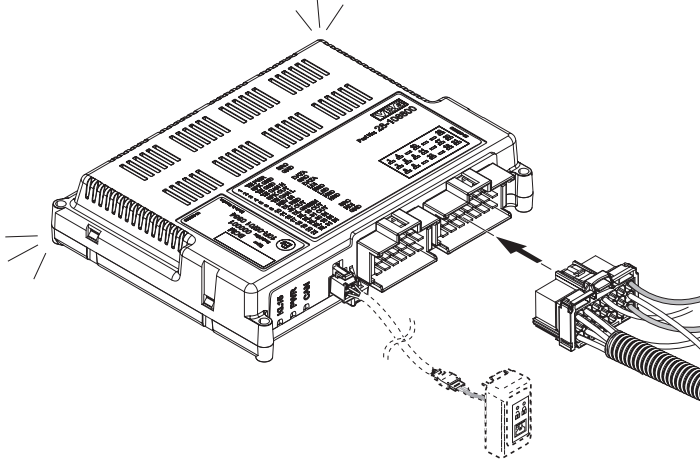

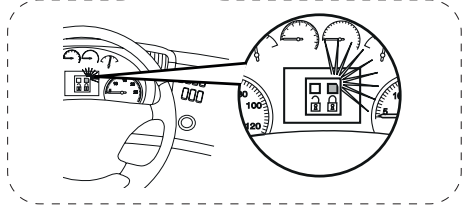
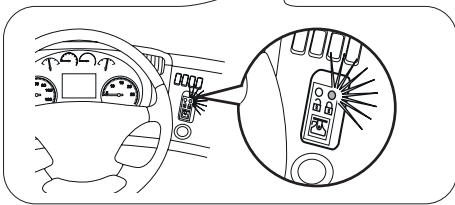
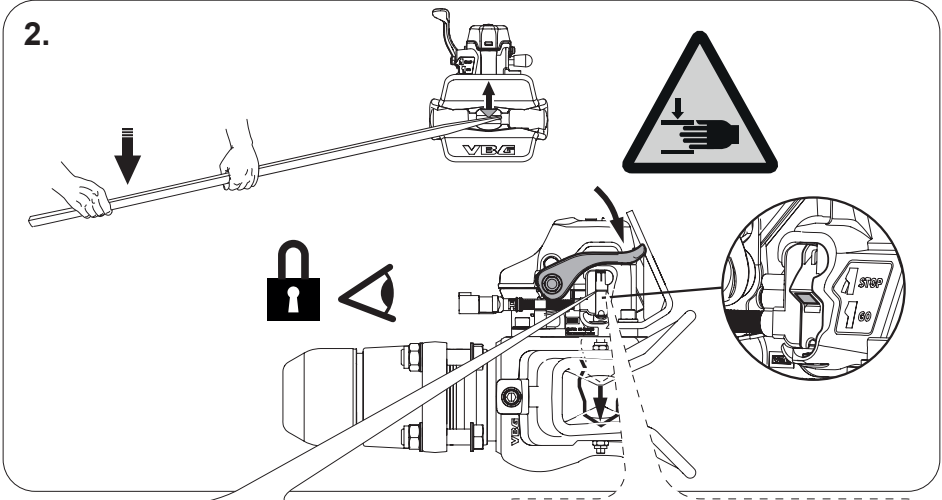
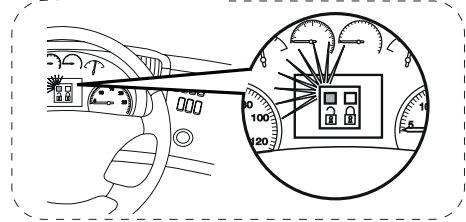
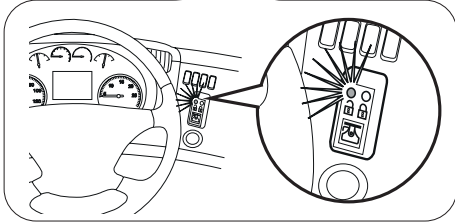
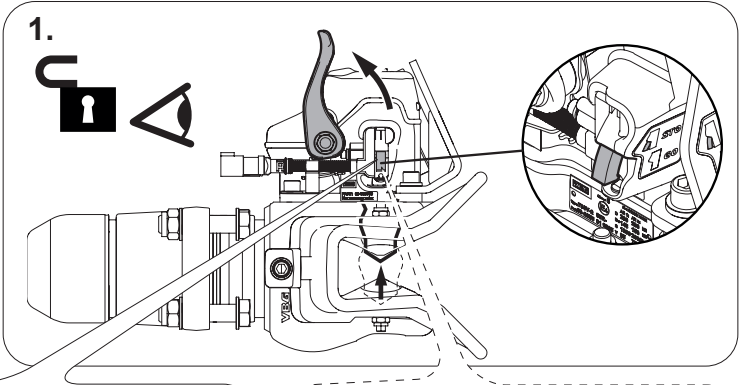
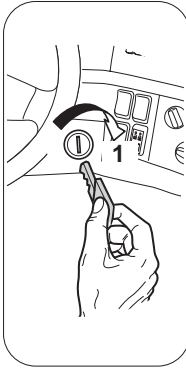

3.

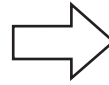
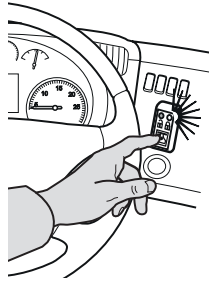
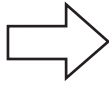
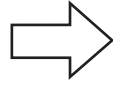
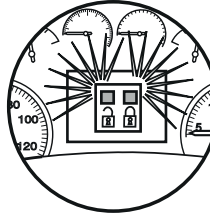
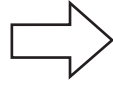
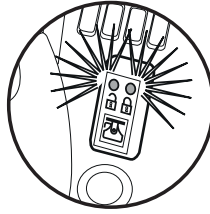
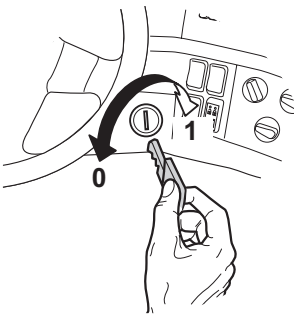



Member of VBG Group

[www.vbg.eu](http://www.vbg.eu)



**The strong connection**