

# MOUNTING INSTRUCTION

2022-09-20 38-339100b

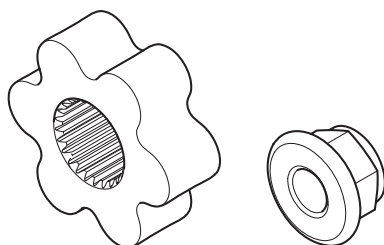

## 09-323300



- 
- |           |  |           |  |
|-----------|--|-----------|--|
| <b>DE</b> | Luftservo Adaptersatz                      | <b>LV</b> | Piedziņas mehānisms,<br>adapteru komplekts |
| <b>DK</b> | Luftservo adapter sæt                      | <b>NL</b> | Power actuator, adapterset                 |
| <b>EE</b> | Toiteajam, adapteri komplekt               | <b>NO</b> | Luftservo adapter sett                     |
| <b>FI</b> | Servo adapterisarja                        | <b>PL</b> | Siłownik zasilania, zestaw adaptera        |
| <b>FR</b> | Actionneur de puissance, kit<br>adaptateur | <b>RU</b> | Силовой привод, комплект адаптера          |
| <b>GB</b> | Power actuator, adapter kit                | <b>SE</b> | Luftservo adaptersats                      |



Montage  
Montering  
Paigaldus  
Asennus

Montage  
Mounting  
Montāžas  
Montage

Montering  
Montażowa  
монтажу  
Montering



Demontage  
Afmontering  
Demonteerimine  
Purkaminen

Démontage  
Dismantling  
Demontāža  
Demontage

Demontering  
Demontaż  
Демонтаж  
Demontering



Funktionskontrolle  
Funktionskontrol  
Talituskontroll  
Toiminnan tarkastus

Vérification des fonctions  
Function check  
Darbības pārbaude  
Funcțiecontrol

Funksjonskontroll  
Kontrola działania  
Контроль функций  
Funktionskontroll



Visuelle Kontrolle  
Visuel kontrol  
Visuaalne kontroll  
Silmämääräinen tarkastus

Contrôle visuel  
Visual check  
Vizuālā pārbaude  
Visuele controle

Visuell kontroll  
Kontrola wzrokowa  
Визуальный контроль  
Visuell kontroll



Klemmgefahr!  
Klemmerisiko!  
Muljumisoht!  
Puristumisvaara!

Risque d'écrasement!  
Pinch point!  
Traumu risks!  
Risico op beknelling!

Klemfare!  
Ryzyko zakleszczenia!  
Риск защемления!  
Klāmrisk!

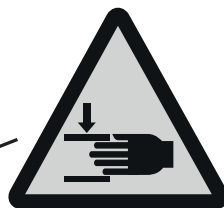
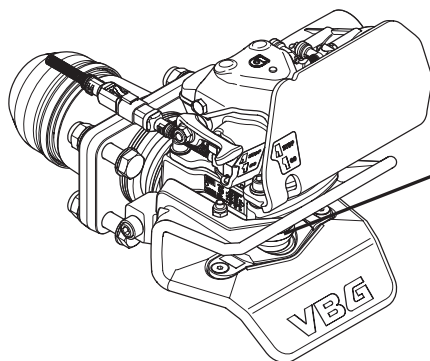

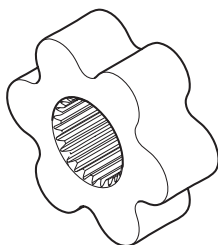
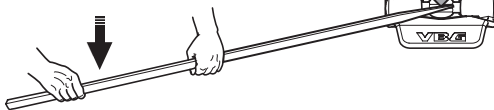

x1



x1

---

**DE Allgemeines**

*Vor der Montage alle Teile identifizieren. Montage und Wartung müssen sorgfältig und fachmännisch durchgeführt werden. Die Anweisungen befolgen.*

**DK Generelt**

*Kontroller at alle dele er til stede inden montering. Montering og service skal foretages omhyggeligt og fagmæssigt. Følg anvisningerne.*

**EE Üldist**

*Määratlege kõik osad enne monteerimist. Paigaldus ja hooldus tuleb teostada hoolikalt ja professionaalselt. Järgige juhiseid.*

**FI Yleistä**

*Tunnista kaikki osat ennen asennusta. Asennus ja huolto on suoritettava huolellisesti ja ammattimaisesti. Noudata ohjeita.*

**FR Généralités**

*Identifier toutes les pièces avant le montage. Le montage et l'entretien doivent être effectués avec le plus grand soin et selon les règles de l'art. Suivre les instructions.*

**GB General**

*Identify all parts before installation. Installation and service should be carried out carefully and professionally. Follow the instructions.*

**LV Vispārēja informācija**

*Pirms montāžas identificējiet visas detaļas. Montāža un serviss ir jāveic rūpīgi un profesionāli. Sekojiet norādījumiem.*

**NL Algemeen**

*Voor de montage moet u alle onderdelen identificeren. Voer montage en service zorgvuldig en deskundig uit. Volg de aanwijzingen.*

**NO Generelt**

*Identifiser alle deler før montering. Montering og service skal utføres nøyaktig og fagmessig. Følg anvisningene.*

**PL Informacje ogólne**

*Zapoznaj się z poszczególnymi częściami przed przystąpieniem do montażu. Czynności montażowe i serwisowe należy wykonywać dokładnie i fachowo. Stosuj się do instrukcji.*

**RU Общая информация**

*Перед монтажом проверьте наличие всех деталей. Монтаж и обслуживание должны осуществляться тщательно и профессионально. Следуйте указаниям.*

**SE Allmänt**

*Identifiera alla delar före montering. Montering och service skall utföras noggrant och fackmannamässigt. Följ anvisningarna.*



1.



2a.

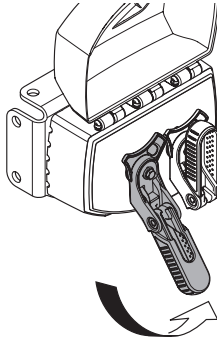
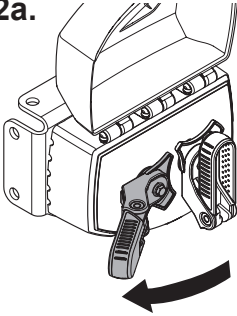

2b.

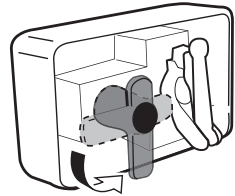

3.

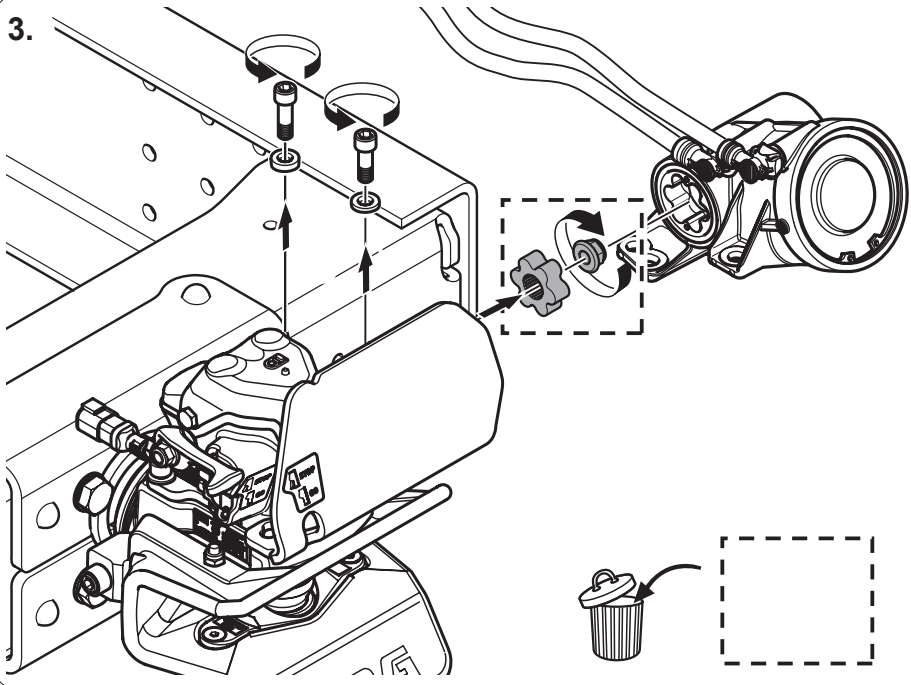



1.

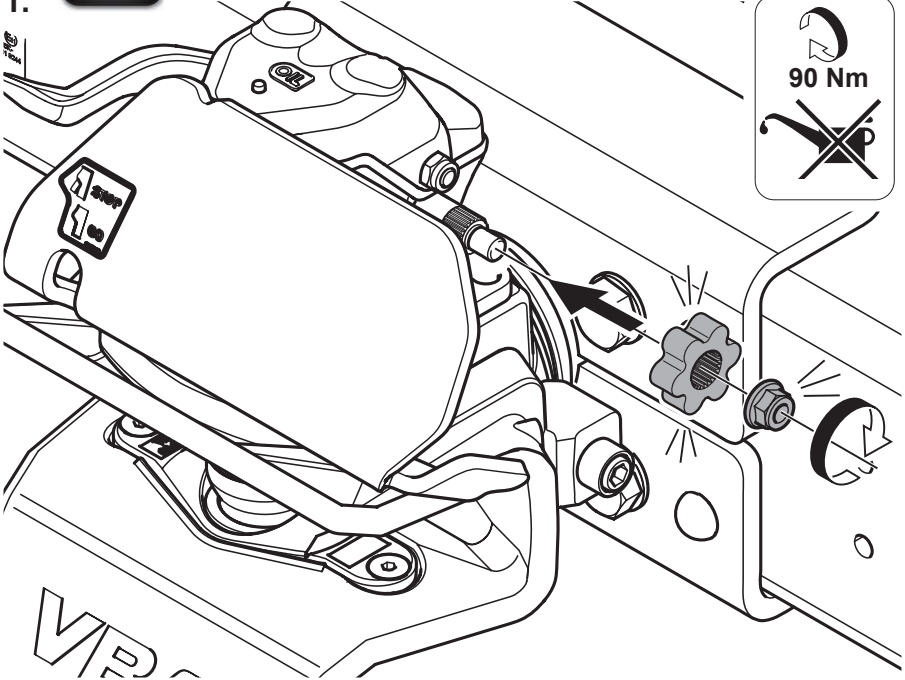

90 Nm



VP

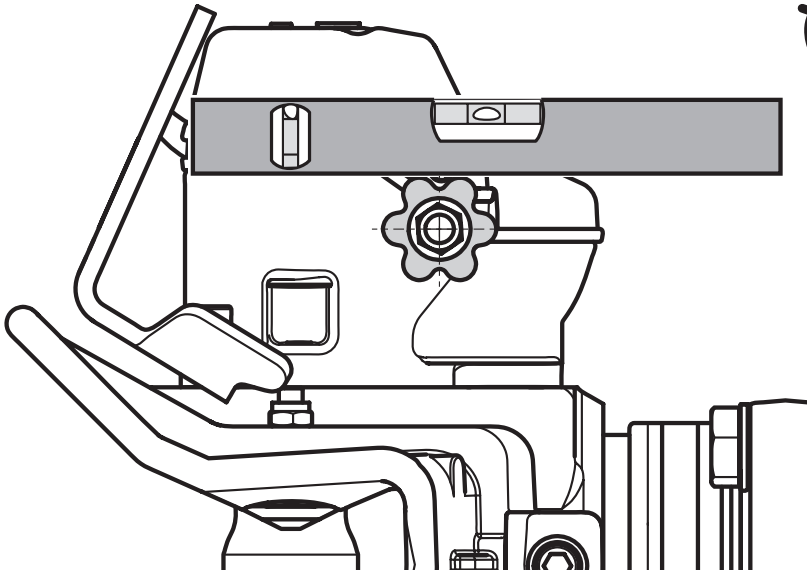

2.

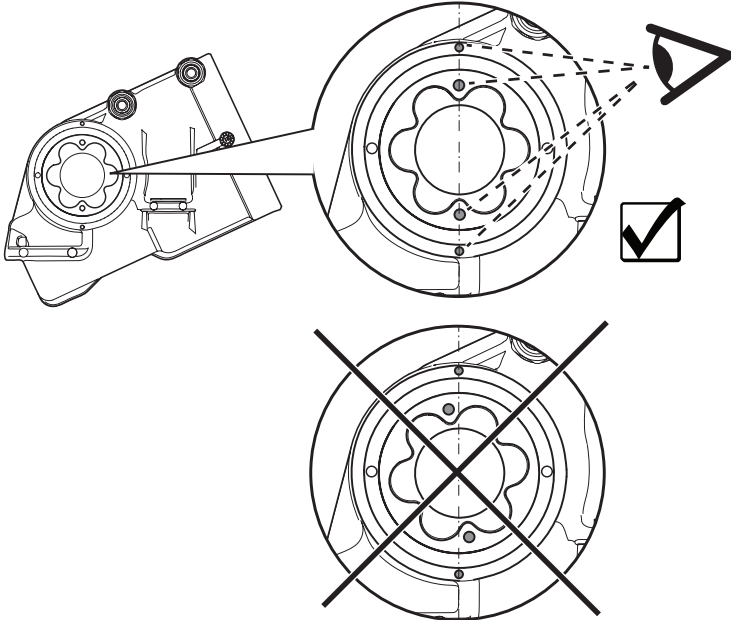

3.

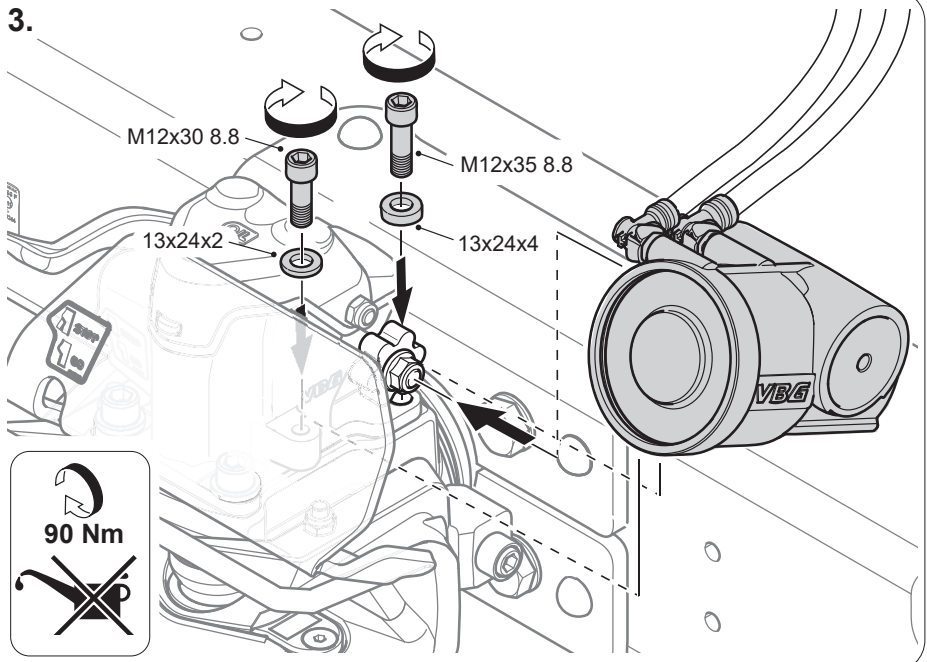

**4a.**

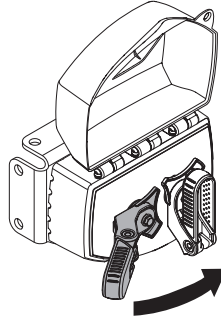
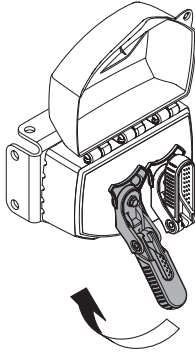

**4b.**

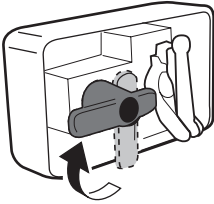



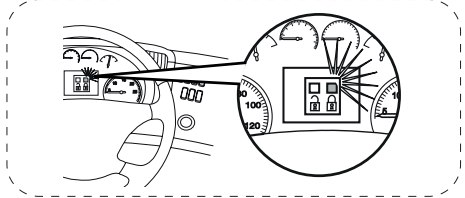
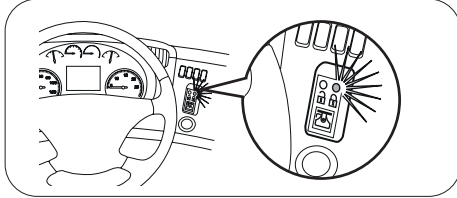
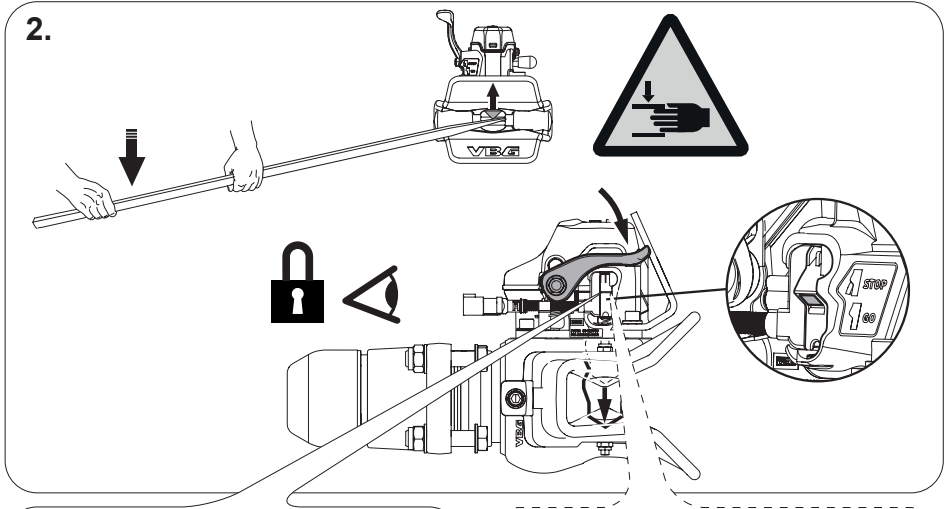
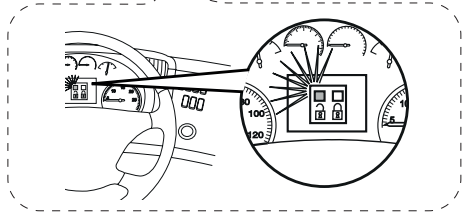
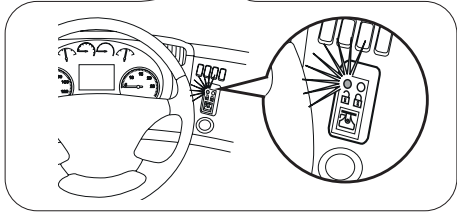
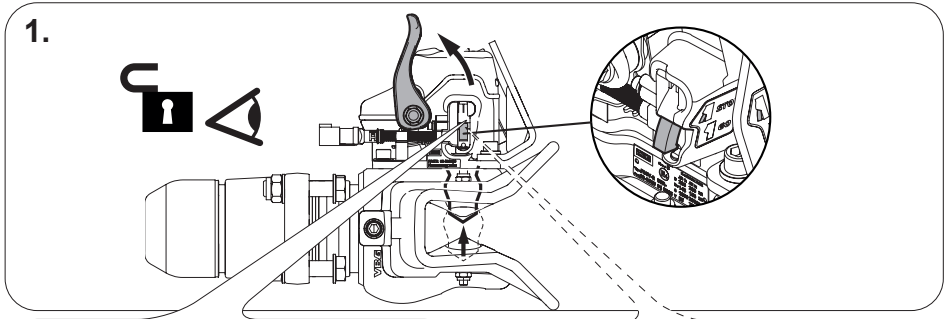





Member of VBG Group

[www.vbg.eu](http://www.vbg.eu)



**The strong connection**